



PUBLIC GATE (RAMPS) POLICY

Objective

To ensure the provision of an efficient, safe and effective road system for the community. In addition, ensure that productivity gains that have been made by opening Council infrastructure to higher productivity vehicles is not compromised by privately held ramps. It should be noted that it is Council's intention is to remove ramps from public roads wherever possible.

Policy

This policy provides Council's requirements for granting permits for the erection of a public gate and delegate's authority to the General Manager to administer sections 128 to 137 of the Roads Act 1993 in accordance with this policy.

All new (replacement) public gates and ramps will be subject to the following requirements.

1. New public gates and ramps will not be allowed on any roads managed by Council.
2. The replacement of existing public gates and ramps will be permitted when required, however the new ramp must meet Councils standard requirements as seen in Attachment 1.
3. Ramps must be removed where road reserves are fenced.
4. The gate and ramp will be installed, maintained and administered in accordance with the requirements of Section 128 to 137 of the Roads Act 1993, and Section 67 to 70 of the Roads (General) Regulation 2000).
5. All costs associated erection of the public gate and ramp shall be met by the owner.
6. Despite the yearly maintenance fee described below, all costs associated with the maintenance of the ramp and concrete base structure shall be met by the owner.
7. Council reserves the right to order the maintenance, replacement or removal of a ramp that does not meet the standard requirements listed in Attachment 1.
8. Council will implement in accordance with the below table, a notification of defect system, that outlines the defect on the ramp and provides a timeline for maintenance, replacement or removal depending upon the degree of deterioration:

Defect Group	Time Permitted to Rectify the Notified Defect
Defect that poses an extreme risk to public safety	48 Hours
Defect that poses a high risk to public safety	7 Days
Ramp defect of moderate risk to public safety	3 Months
Ramp defect of minor risk to public safety	18 Months
Ramp requiring removal notice	3 Months
Ramp requiring replacement notice	3 Months

9. If the owners of the ramp do not complete the required works within the above defect response time, Council reserves the right to order the removal of the ramp to ensure public safety.
10. Where ramps are shared between two individual landholders, the whole cost will be exactly halved. Where one individual has installed fencing and therefore no longer requires the ramp, the whole cost will be borne by the landholder that has not fenced the road reserve.

TRANSPORT & COMMUNICATIONS POLICIES



PUBLIC GATE (RAMPS) POLICY

- 11. Where Council is unable to identify an owner of a ramp, adjoining landholders will be notified and the ramp will be removed.
- 12. Council will contribute to the removal of any ramp that falls within this policy by allocating machinery and labour to reinstate the disturbed road surface. This work must be coordinated with Council Staff, as this will only occur when Council crews are already undertaking maintenance or construction activities in close proximity to the ramp.

Ongoing Maintenance of Ramps:

In order to ensure the safe, effective and ongoing maintenance of public ramps, Council will assume the responsibility of maintaining the ramp surrounds. In doing so, Council will charge the following annual fees for the maintenance of each public ramp.

Service:	Annual Fee (Ex GST)
Yearly Maintenance Fee	As detailed within Councils Fees and Charges
Cleaning of Gravel / Debris in the Ramp	Quoted for each occasion.
Maintenance of Ramp and Concrete Base	Quoted for each occasion.

The yearly maintenance fee is for the following services:

- Maintenance of the road to the ramp (grading, pothole patching, drainage).
- The administrative requirements of gathering, storing and updating insurances and certification of the ramp.
- The administrative requirements of inspecting and reporting on ramp integrity.

In order to be eligible for exemption from the Yearly Maintenance Fee, the ramp owner must lodge all required insurance, competency and plant certification to Council. If all documentation meets Council’s requirements, the ramp owner will be permitted to complete the required maintenance on the ramp approaches. All documentation must be maintained in accordance with the relevant legislation.

Delegation of Authority

The implementation of this policy is bound by the requirements of Division 2, Part 9 of the Roads Act 1993 and the supporting regulations which provide the Council, as the roads authority, with the power to issue and revoke permits for the installation of public gates and bypass structures across public roads. For the purpose of exercising this function, Council has delegated the function to the General Manager pursuant to section 322 of the Local Government Act. The delegation includes the creation and ongoing review of guidelines to assist the public to apply for, construct and maintain public gate infrastructure.

Supersedes Previous “Transport & Communication Policies – Ramps” – DD/2410
Adopted Council Meeting 26 August 2009 – Minute No.: 25/2009-2010
Amended & Adopted Council Meeting 25 October 2017 – Minute No.: 65/2017-2018
Amended and Adopted Council Meeting 13 December 2017 – Minute No.: 92/2017-2018



PUBLIC GATE (RAMPS) POLICY

Attachment 1:

Walcha Council Standard Ramp Specifications (Note that this can be reversed with the gate and / or channel on the other side of the ramp)

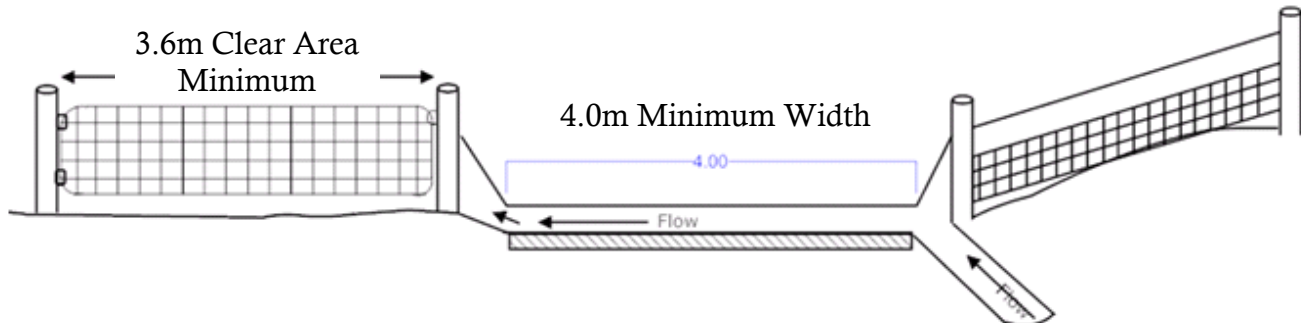

Standard Ramp Outlay:

Standard Ramp Concrete Base (Left Hand Side) – Cross Sectional View:

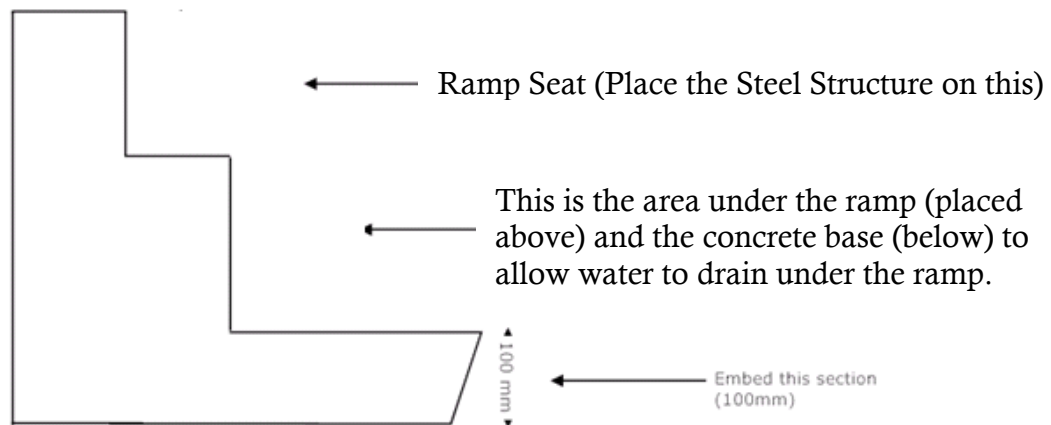

1. A gate with a clear opening of at least 3.6 metres shall be erected to one side of the existing road alignment.
2. A stock ramp shall be installed with its centreline corresponding to the centreline of the existing road.
3. The ramp must be installed with a concrete base that allows water to flow under the ramp as specified in the above drawings.
4. The ramp must be installed with appropriate “wings” that do not face oncoming traffic.
5. The ramp shall be certified by a structural engineer as being capable of carrying normal highway loading to comply with the current Australian Standard.
6. The ramp shall have a clear opening of at least 4.0m.
7. The ramp shall have appropriate signage, installed in accordance with the Roads Act 1993.